

The history of revision change for the specification

Document	REV.	Modified date	Description
CYNVF-207-002	A0	2020.7.2	New Approval
CYNVF-207-002	A1	2022.02.23	1. Jul., 2020 -> Feb., 2022 2. Add the coplanarity in the dimensions 3. Year code 2020 = 0 -> 2022 = 2
CYNVF-207-002	A2	2023.12.07	1. Feb., 2022 -> Dec., 2023 2. Year code 2022 = 2 -> 2023 = 3 3. Add Specifications Note6: We do not recommend the use of conformal coating, please discuss with us if you have this requirement.

AEC-Q200

Wire-wound Common Mode Choke VFC3225 Series

■ Features

- High-level mode conversion Scd21 performance
- Operating temperature -55°C~150°C
- Suitable for lead-free reflow soldering
- Compliance with RoHS and Halogen Free
- AEC-Q200 qualified

■ Application

- Used radiation noise suppression for automotive CAN-BUS/CAN-FD/Flex Ray/A²B (Audio Bus) systems
- Used for Industrial field bus systems

■ Outline Dimensions

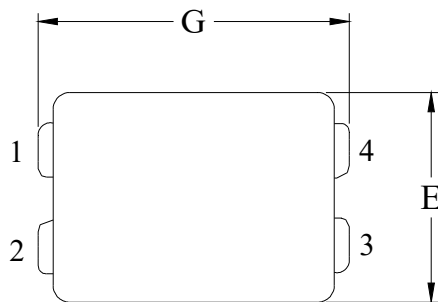

Code	Dimensions (mm)
A	3.4 Max.
B	0.6 ± 0.1
C	0.5 ± 0.1
D	0.5 ± 0.1
E	2.5 ± 0.2
F	2.6 Max.
G	4.0 Max.

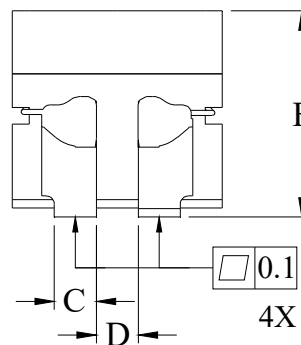
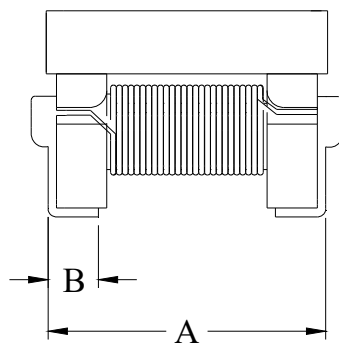

■ Schematic

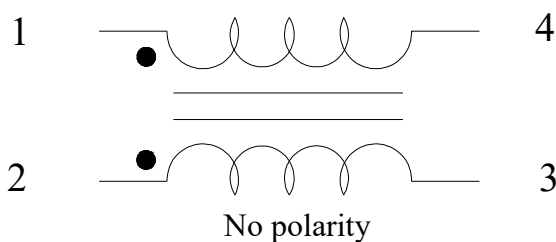

■ Recommend Land Pattern Dimensions

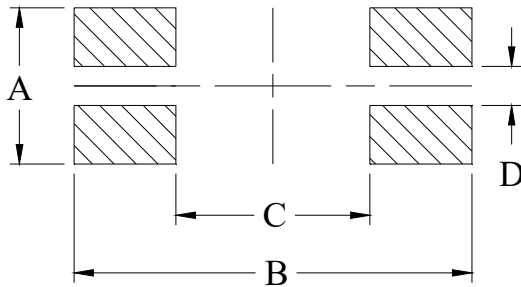

A	1.6
B	4.1
C	2.0
D	0.4

Unit : mm

■ Marking and Date Code

(1) Marking

The inductor is marked with a 3-digit code

Example -- 100 μ H → 101

(2) Date Code

X XX XXX
 (1) (2) (3)

Where (1) Year Code

Ex : 2023 = 3

(2) Weekly Code

Serial number : 01 ~ 53

(3) Taping No.

Serial number : 001 ~ ZZZ

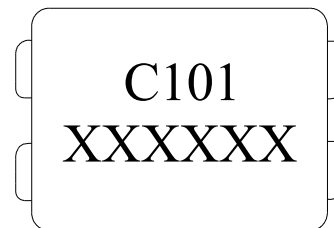

■ Specifications

Part Number	Common Mode Inductance (μH) Note2 ◇	Stray Inductance (μH) Note2	Common Mode Impedance (Ω) Note3		DCR (Ω) ◇	Rated Current (mA)	Rated Voltage (Vdc)	Insulation Resistance ($\text{M}\Omega$)
		Typ.	Min.	Typ.	Max.	Max.	Max.	Min.
VFC3225-101	100	0.13	2200	5100	2	150	80	10

◇ : Significant Characteristic

*Inductance Tolerance : -30% / +50%

Note 1. : All test data is referenced to 25°C ambient.

Note 2. : Test Condition:100KHz, 0.1Vrms

Note 3. : Test Condition:10MHz, 0.1Vrms

Note 4. : Operating Temperature Range -55°C to +150°C

Note 5. : Cleaning Process Note

(a) If this power choke is dipped in the cleaning agent, such as toluene, xylene, ketone, and ether system, there is a possibility that the performance decreases greatly

(b) The high power ultrasonic washing may damage the choke body.

(c) Please contact us if you need the cleaning via the above agents or ultrasonic washing.

Note 6. : We do not recommend the use of conformal coating, please discuss with us if you have this requirement.

■ Impedance VS. Frequency Characteristic

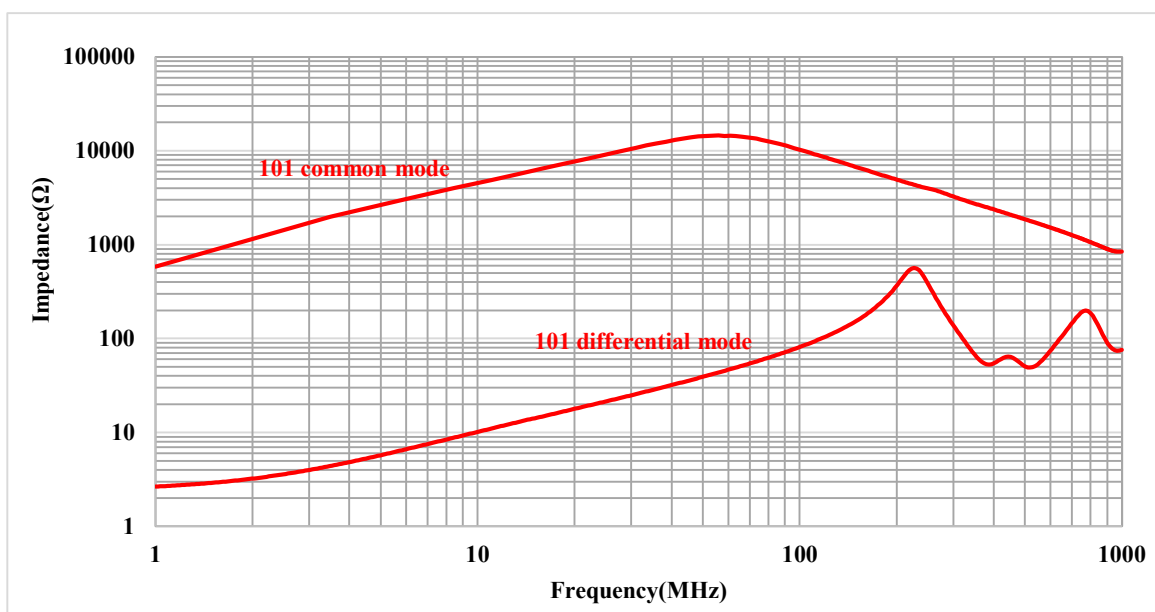

■ Packaging

(1) Tape packaging dimensions

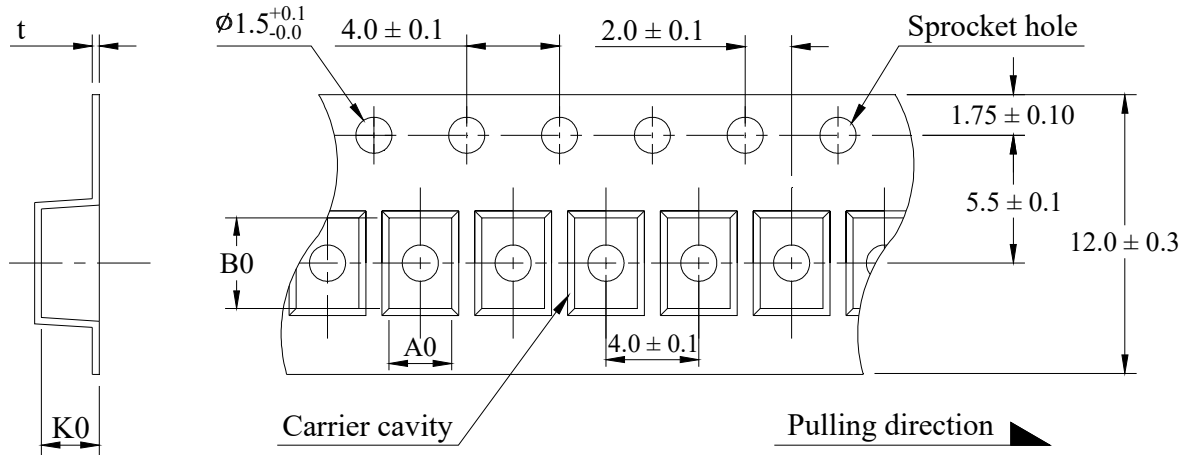

Dimensions Code (mm)				UNITS/REEL
A0	B0	K0	t	
2.7 ± 0.1	3.9 ± 0.1	2.8 ± 0.1	0.35 ± 0.10	5,000

(2) Tape direction

The direction shall be seen from the top cover tape side.

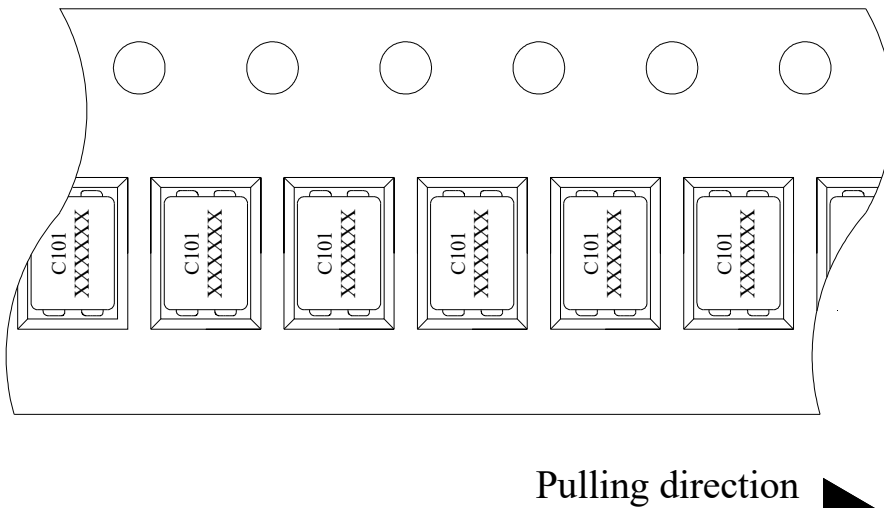

(3) Reel dimensions

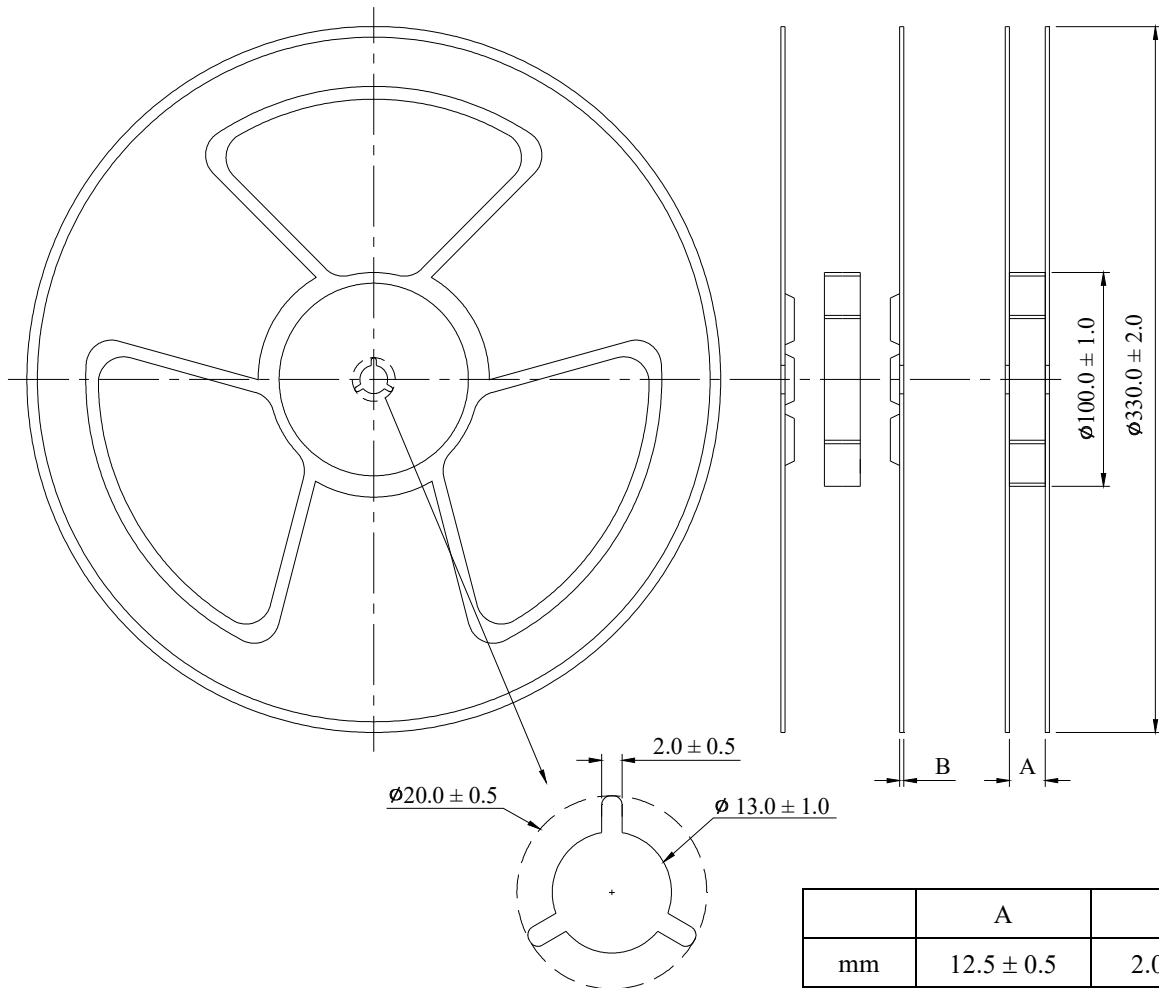

(4) Peel force of top cover tape

The peel speed shall be about 300 mm/minute.

The peel force of top cover tape shall be between 0.1 to 1.3N.

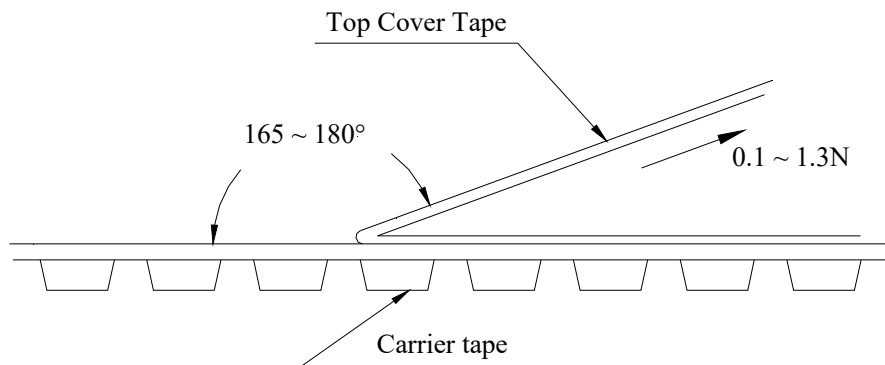

■ Reflow profile

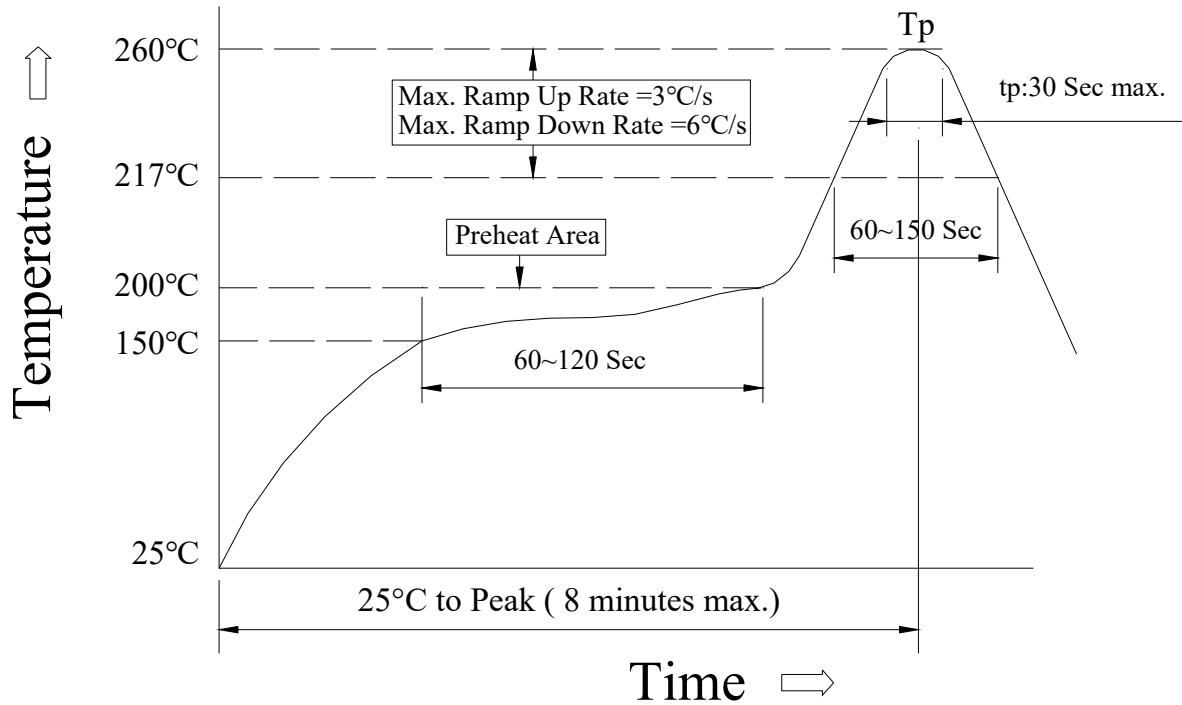

(1) Reflow Soldering Method :

Reflow Soldering	Tp:255~260°C	Max.30 seconds (tp)
	≥217°C	60~150 seconds
Pre-Heat	150 ~ 200°C	60~120 seconds
Time 25°C to peak temperature	8 minutes max.	

(2) Soldering iron Method : 350 ± 5°C max.3 seconds